

THE NEXT GENERATION OF  
ORBITAL WELDING EQUIPMENT

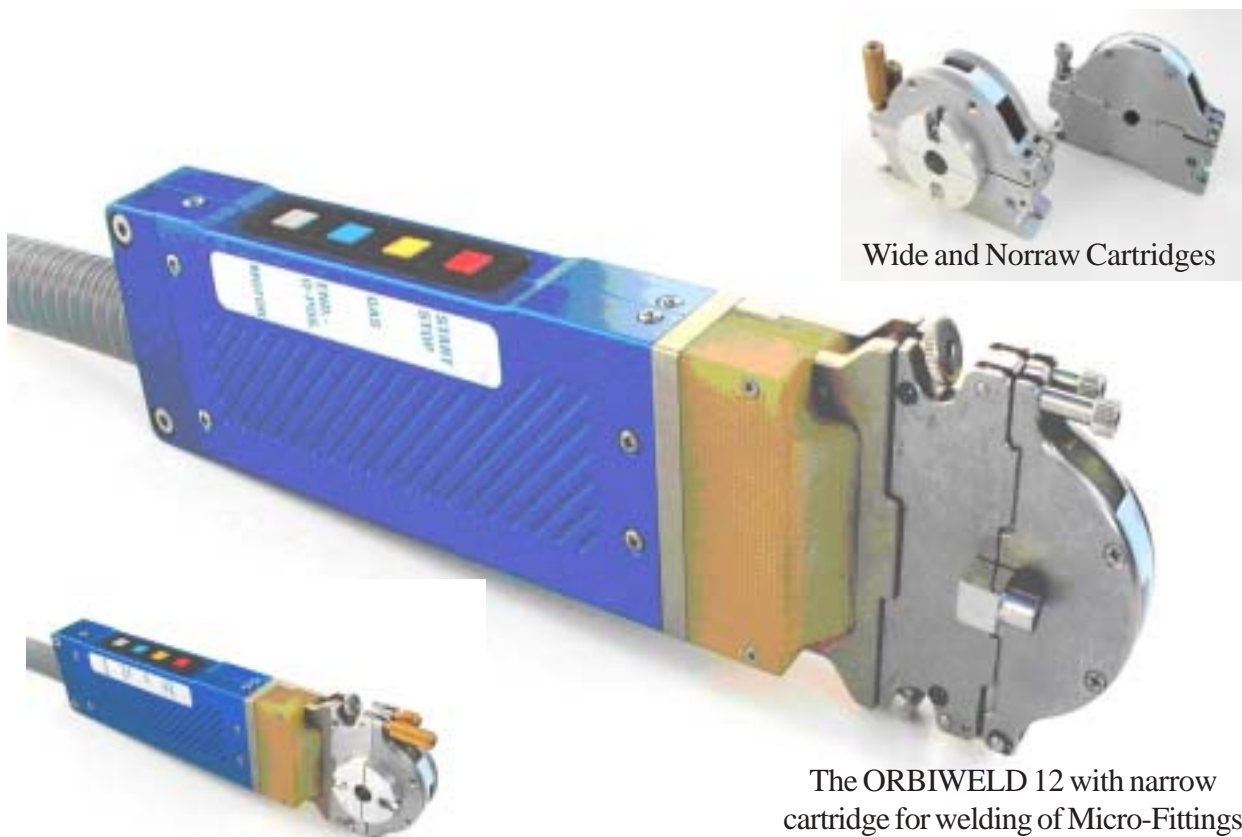

# ORBIWELD 12

Water Cooled Micro Weld Head



The ORBIWELD 12 with wide cartridge for normal applications

The ORBIWELD 12 with narrow cartridge for welding of Micro-Fittings

The *ORBIMATIC* ORBIWELD 12 Micro Weld Head, is extremely compact in design and has several cartridge options, offering a unique flexibility. The head is designed with an internal water cooling system which gives the ORBIWELD 12 high operating duty cycles despite its compact design.

When combined with the ORBIMATIC range of Orbital Welding Power Supplies you will get a highly advanced orbital welding system which offers full flexibility.

The ORBIWELD 12 uses a quick release cartridge systems which allows cartridges to be changed in seconds. There are two styles of cartridge available for use with the ORBIWELD 12.



The first is a narrow cartridge which is designed specifically for welding of 'Micro-Fittings' which have minimal weld stub. When these narrow cartridges are used with 'Micro Fittings' the edge of the square of offered against the side of the cartridge and this gives exact alignment to the tungstene electrode.



With the narrow cartridge a separate cartridge is required for each different tube diameter being welded.

The second is a wide cartridge which can be used for tube to tube work or for welding longer stub fittings. The wide cartridge is fitted with removable collets which can be exchanged for each different tube diameter being welded.

ORBIMATIC can also produce combined cartridges which give the benefit of both cartridge types for some special applications, such as the welding of valves and regulators.



For ease of operation the ORBIWELD 12 has a control panel built into the weld head handle. This control panel allows for basic operation of the welding systems from the weld head.

Control function from the weld head include START, STOP, END, Gas Purge Rotor Jog and return to home position.

The ORBIWELD 12 is supplied in a robust transportation case with a tool kit which contains all essential tools for the operation of the process.

The ORBIWELD 12 can be used with any ORBIMAT orbital welding power supply to give a high technology orbital welding system.

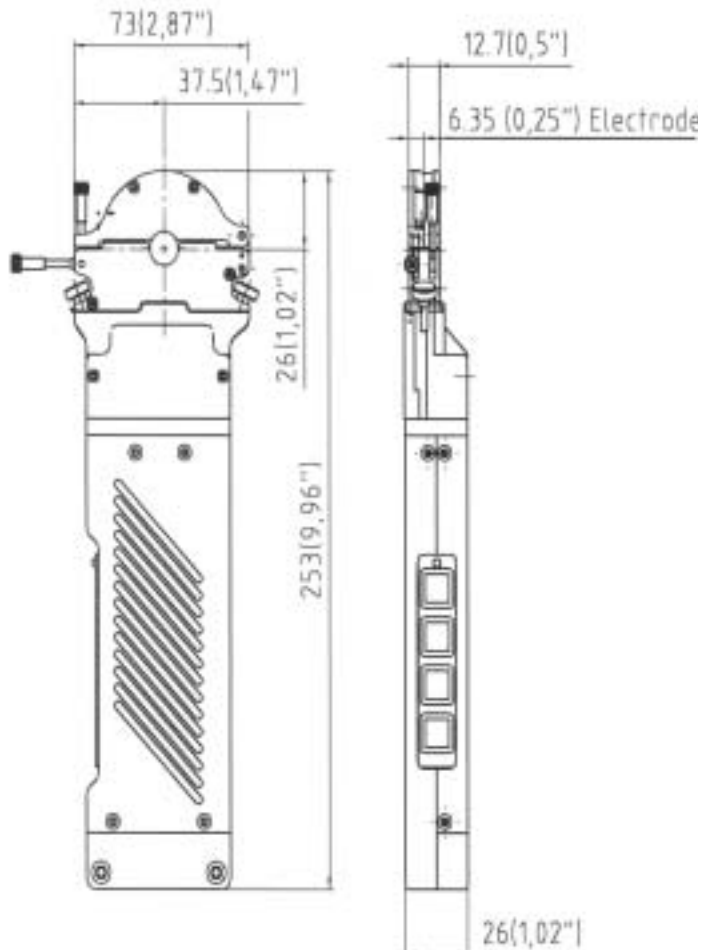

**ORBIMATIC GmbH**  
 Floesser Weg 17  
 D-35418 Buseck / Germany  
 Tel. +49 6408 9026 0  
 Fax +49 6408 9026 50  
 E-mail: Orbimatic@t-online.de  
 Website: <http://www.orbimatic.com>

**ORBIMATIC GmbH**  
 PO Box 416, Peterborough  
 Cambridgeshire, PE7 3FT, UK  
 Tel. +44 1733 244063  
 Fax +44 1733 244463  
 E-mail: [info@orbimatic.co.uk](mailto:info@orbimatic.co.uk)  
 Website: <http://www.orbimatic.co.uk>